

# Optima<sup>®</sup>

## UNDER VEHICLE INSPECTION SYSTEM

### UVIS-100

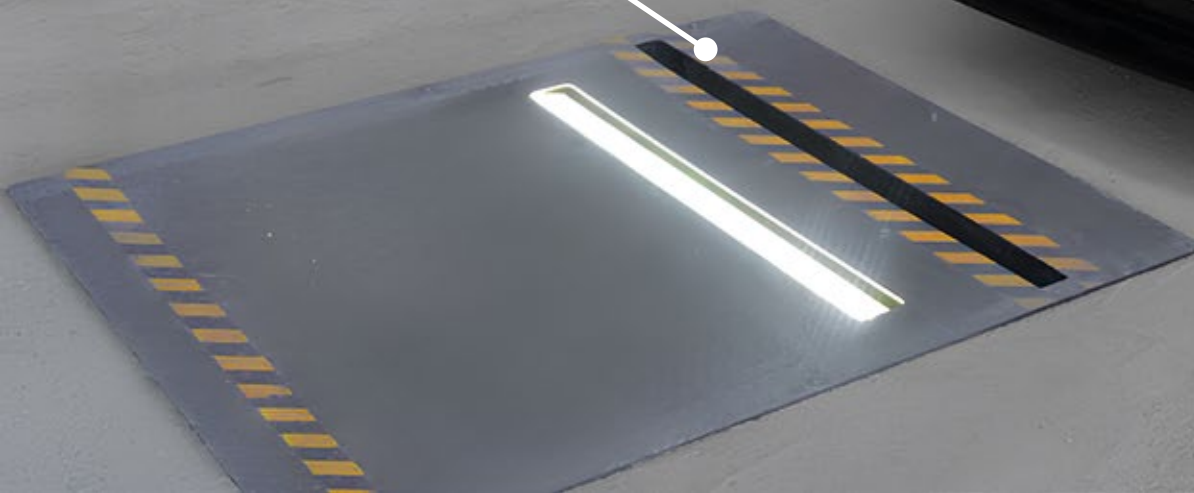

# Security Systems

## FLUSH MOUNT UVIS-100 UNDER VEHICLE INSPECTION | **UVIS-100**

OPTIMA UVIS-100 systems are designed with advanced security technology to scan, inspect and record underside of all vehicles. These systems are used especially for entrances where there is a threat of suicide vehicle attack with explosives or for the entrances that have very high-security requirements like army, industrial, governmental and commercial buildings, sites, complexes, etc.



## SYSTEM FEATURES

MODELS	UVIS-100
Industrial Area Scan Camera	<ul style="list-style-type: none"><li>-Color Camera</li><li>-Frame Rate per second 500 fps</li><li>-Image Data Interface Gigabit Ethernet (1000 Mbit/s)</li></ul>
Camera Lens	<ul style="list-style-type: none"><li>-Focal length f= 5 mm</li><li>-Maximum diameter ratio is F= 1:2.8 ~16</li></ul>
Vehicle Detection Sensor	<ul style="list-style-type: none"><li>-Power Requirements: 12-24V AC/DC +/-15% 1.5VA max @230 V</li><li>-Output Relay: N.O contacts (fail-safe in presence mode) or N.C. model</li><li>-Material: High Heat ABS blend</li><li>-Dimesions:78(H) x 41(W) x 80(L) mm</li><li>-Mounting: Shelf or DIN-rail socket</li><li>-Connector: Single rear mount 11-pin submangal</li></ul>
Processing Unit	<ul style="list-style-type: none"><li>-CPU Intel Core™ i7.</li><li>-System Memory 2 x 204-pin DDR3-1333/1600MHz SO-DIMM, up to 16GB.</li><li>-NVIDIA GeForce GPU</li><li>-Min 250 GB M2 SSD + Min 1 TB HDD</li></ul>

Environmental Conditions and Power Requirements	- -20°C/50°C & 12-24 V DC
Material	St37 Steel & Stainless Steel top cover
Top cover thickness	5 mm
Body colour	RAL 7012
Self Cleaning System	Optional
Power Consumption / Insurance Value	1 kW / 6 Amper Fuse

- Taking a picture of the underside of the vehicle with a high resolution automatic digital area scanner camera and displaying it on the screen.
- Alert on the monitor when a suspicious object is detected under the vehicle.
- Ability to scan vehicles moving at 0-50 km/h from both sides in two directions.
- Easy integration with many physical security products such as road blocks, barriers and license plate recognition systems.
- The ability to track the information recorded from the web interface from anywhere in the world.

## OPTIONAL FEATURES

BASIC PRODUCT	UVIS-100	Scan and investigate under side of the vehicle
Option 1	ALPR 100+ White/Black List Software	Recognition of the vehicle plate; compare current and previous images of underside of that particular vehicle. If a vehicle is added to "Black List"; barrier, road blocker whichever is integrated to the system will not let the vehicle enter when the plate added to black list is matched with recognized plate. In addition, operator is warned both audibly and visually. If a vehicle is added to "White List"; barrier, road blocker whichever is integrated to the system will let the vehicle enter when the plate added to white list is matched with recognized plate
Option 2	ALPR 100+Vehicle Brand, Color & Type Recognition	Compare license plate with the color, type & brand of the vehicle with previous images
Option 3	ALPR 100+Alarm Software	Recognition of the vehicle plate; compares and gives an alarm(both sound alarm and red frame work) in case software detects major image differences under the vehicle
Option 4	ALPR 100+Integration of the Governmental Systems Databases	Recognition of the vehicle plate; compares and gives an alarm(both sound alarm and red frame work) in case software detects major image differences under the vehicle
Option 5	Driver Image Capture Camera	Captures the image of the driver's face and displays on the screen for manual comparison by the operator
Option 6	Suspect Objects Detections	In case of suspected objects, there will be red frame marks on the image
Option 7	Traffic Light	Red / Green Light

# BODY MEASUREMENTS

## APPLICATION VIEW



## PERSPECTIVE VIEW

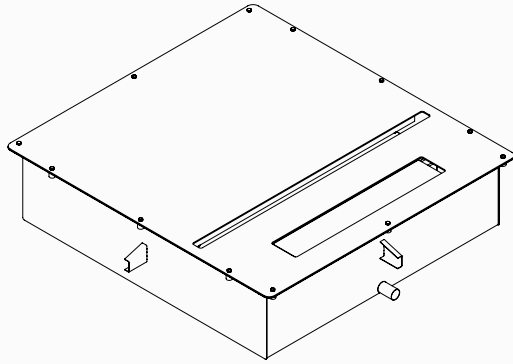

## TOP VIEW

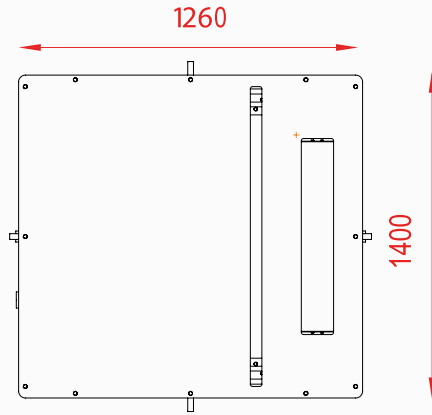

## SIDE VIEW

